

# Introduction to DAQ Hardware and LabVIEW Application Software

Prepared by Kalyan C. Simham  
as instructed by Prof. M. Kostic  
8<sup>th</sup> August, 2007

## OBJECTIVES:

- I) To show different sensors/transducers and data acquisition hardware components using newly-developed ILS apparatus.
- II) Use the LabVIEW software to read analog input from a function generator and displays the output in waveform chart.
- III) To show how to perform basic LabVIEW operations and using the built functions.

## EXPERIMENT I

AIM: Create a simple LabVIEW file to demonstrate basic arithmetic operations of numbers and finding square root, inverse and product of the numbers.

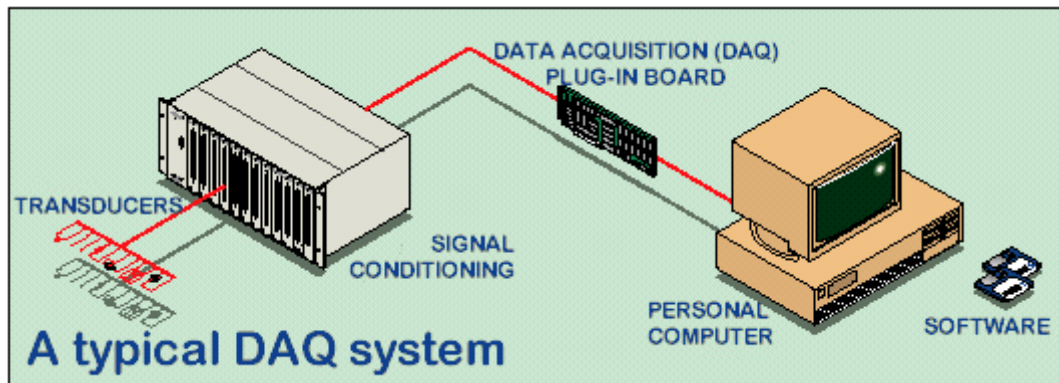

Fig 1: DAQ System Reference [1]

## Procedure:

- 1) Start LabVIEW application Software from the programs and open a new file.
- 2) The two windows are opened; one is called Front Panel and the other Block Diagram.
- 3) Right click on the front panel opens a pop up menu which display numerous controls/indicators (i.e. inputs/outputs) provided by the software.
- 4) Select the numerical controls and place it on the Front Panel, repeat the step for creating another numerical control.
- 5) Similarly select a numerical indicator from the pop-up menu. Repeat step twice to create another two numerical indicator as shown in the Fig 1

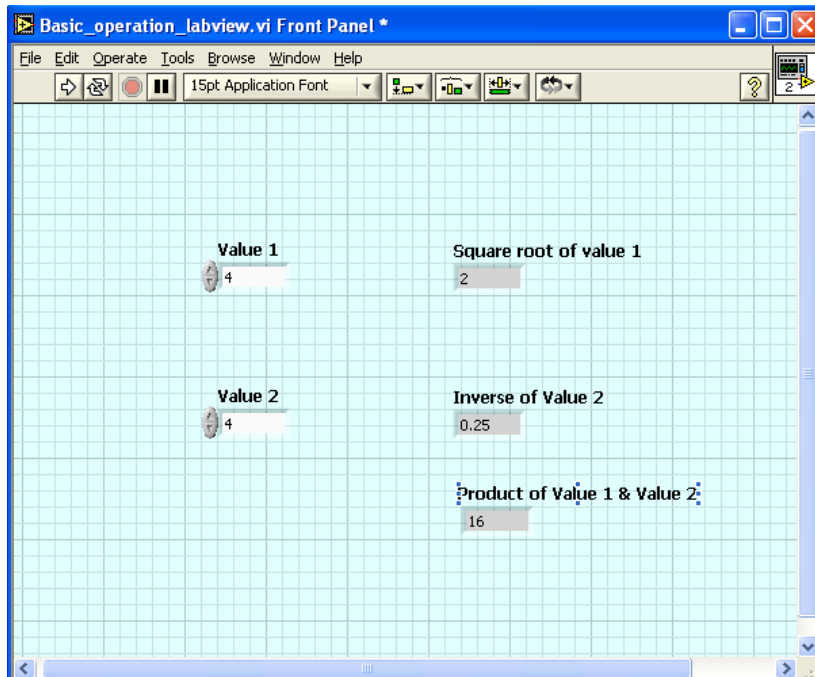

Fig 2: Front Panel with Numerical Controls and Numerical Indicator

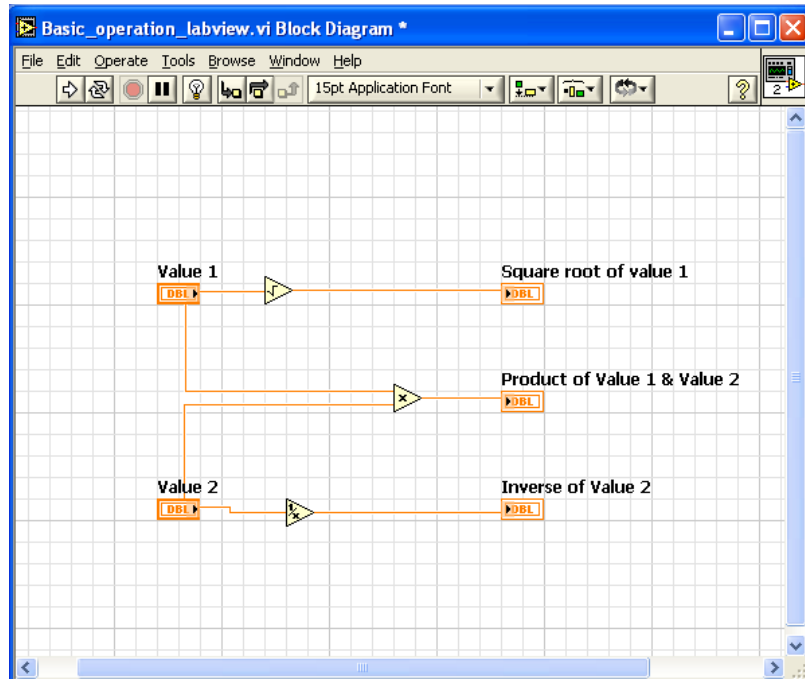

Fig 3: Block Diagram with Numerical Functions

- 6) Now shift to the Block Diagram window and right click on it to open the functions pop-up menu. Select the numerical functions from the menu.
- 7) Connect (or wire) the numerical controls and the indicators with the numerical functions as shown in the Fig 2.
- 8) Now vary the values in the numerical controllers (inputs) and click the run (right arrow) button.
- 9) The corresponding square root of value1, inverse of value2 and product of value1 and 2 are displayed in the numerical indicators (outputs).

## EXPERIMENT II

AIM: To measure the analog input from a function generator by DAQ hardware and to display corresponding output in wave form using the LabVIEW software.

### Procedure:

- 1) Connect the function generator output to the DAQ Terminal Block input channel using BNC wires.
- 2) Start LabVIEW application software from the programs and open a new file.
- 3) The two windows are opened, one is said to be Front Panel and other Block Diagram
- 4) Create a DAQmx virtual channel of analog input.
- 5) Connect to the DAQmx read to read the connected channel of analog voltage input.
- 6) Create an indicator to display the data from DAQmx read.
- 7) Check for the connection errors.
- 8) Shift to Front Panel window and create a waveform graph.
- 9) Connect DAQmx data output to the waveform graph in the Block Diagram window.
- 10) Select the input channel to which the function generator is connected.
- 11) Run the software in the continuous loop mode to start the reading of function generator signal.

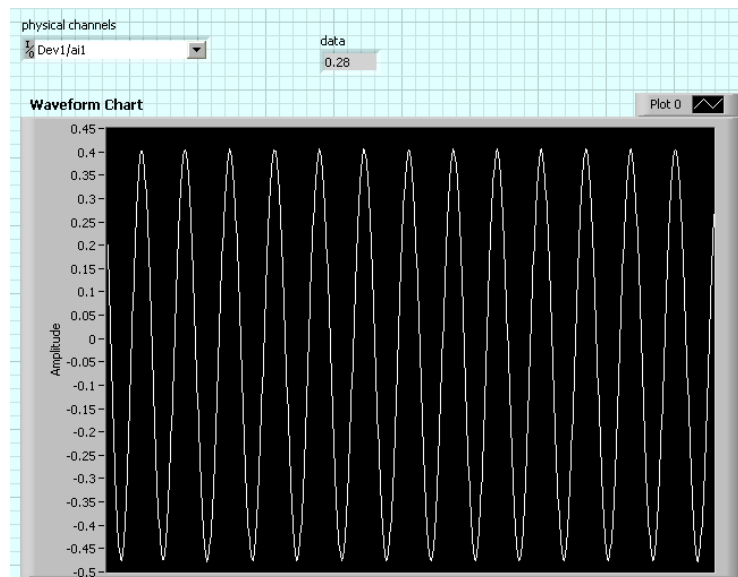

Fig 4: Front panel with Sine waveform graph from the function generator

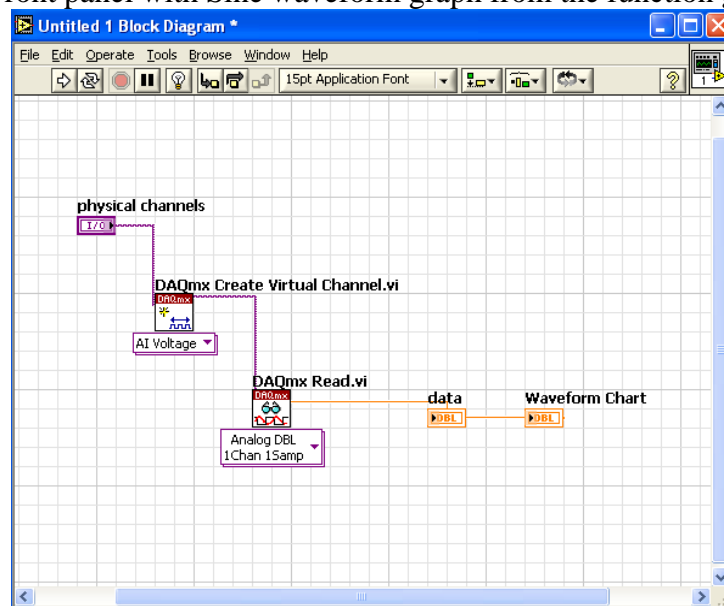

Fig 5: Block diagram to read the analog input form the function generator

## References:

1. **MEE 390 Lab Handout:** <http://www.kostic.niu.edu/DAQ-LabVIEW.html>

Kostic, M., Srinivasa Rao Vaddiraju, Srinivas Majji, Shashank B. Tirumala, and Dan Wu, “*Design of Modern, Integrated Laboratory- Stations (ILS) for Engineering Experimental Courses,*” **ASEE-2005 IL-IN Section Conference**, American Society for Engineering Education, DeKalb, IL, April 1-2, 2005.

[http://www.kostic.niu.edu/ASEE-IL\\_IN\\_05-P135.pdf](http://www.kostic.niu.edu/ASEE-IL_IN_05-P135.pdf)