

Design of Extrusion Dies

Milivoje M. Kostic

*Department of Mechanical Engineering, Northern Illinois University,
DeKalb, Illinois, U.S.A.*

Louis G. Reifschneider

Department of Technology, Illinois State University, Normal, Illinois, U.S.A.

INTRODUCTION

The goal of this chapter is to introduce the reader to the importance of extrusion die design as well as the complexities inherent in the task. Extrusion is of vital importance to all plastics processing. In addition to providing raw stock such as sheet for thermoforming and pellets for injection molding and other extrusion processing, numerous end-use products are made with extrusion such as film, tubing, and a variety of profiles. Although the types of extruded products made can differ dramatically in shape, there are a set of common rules that govern basic die design. For example, it is important to streamline the flow from the inlet to the exit, and as a practical measure, to fine-tune the flow balance and product dimensions, flow adjustment devices could be included in the die design.

Several unique products are made by extrusion and the dies needed to make these products are classified as: 1) sheet dies; 2) flat-film and blown-film dies; 3) pipe and tubing dies; 4) profile extrusion dies; and 5) co-extrusion dies. Furthermore, each product type has unique hardware downstream of the die to shape and cool the extruded melt. To aid the reader, detailed illustrations of the various die designs and the complementary downstream cooling and shaping hardware are shown.

Predicting the required die profile to achieve the desired product dimensions is a very complex task and requires detailed knowledge of material characteristics and flow and heat transfer phenomena, and extensive experience with extrusion processing. Extrusion die design is still more an art than a science, even though the latter is becoming more and more relevant for design optimization because of recent advancement in the powerful computation and modeling of complex flow and heat transfer processes, before, through, and after the die.

DESIGN FUNDAMENTALS

Extrusion is a continuous process where solid polymeric materials, either pellets or powders, are sheared

and heated as they are conveyed through either a single- or a twin-screw extruder (as described elsewhere) to become a pressurized melt. The pressurized melt flows through a properly shaped orifice, or extrusion die, and then is pulled (with a little pressure) as it is cooled and shaped to a final product called the extrudate. The proper design of an extrusion die is extremely important to achieve the desired shape and accurate dimensions of the extruded product. The function of an extrusion die is to shape the molten plastic exiting an extruder into the desired cross section depending on the product being made. The die provides a passage between the circular exit of the extrusion barrel and the more complex and often much thinner and wider die exit. A schematic of a common die, called a sheet die, is shown in Fig. 1A to illustrate this point. The extrusion process creates products of uniform cross section in a continuous fashion. An ideal passage will:^[1,2]

- Balance the melt flow by providing a more uniform exit velocity across the entire die exit.
- Achieve this flow balance with a minimal pressure drop.
- Streamline the flow to avoid abrupt changes in the flow passage that may cause stagnation areas. Stagnated flow may lead to thermal degradation of the plastic melt as the melt is exposed to high heats for long periods.

As a practical measure, flow control devices should be incorporated into the die design to permit fine-tuning of the die passage shape to ensure a proper flow balance. In addition, the design of extrusion dies is complicated by two unique material properties of molten plastics:^[3]

- Melts exhibit shear thinning behavior (become less viscous) as they are sheared.
- Melts exhibit viscoelastic behavior, which influences the “die swell” on exiting the die.



Fig. 1 Coat hanger-type sheet die concept (A): (1) central inlet port; (2) manifold (distributes melt); (3) island (along with manifold, provides uniform pressure drop from inlet to die lip); (4) die lip (die exit forms a wide slit); and schematic of sheet die (B): (1) upper die plate; (2) lower die plate; (3) manifold; (4) island; (5) choker bar; (6) choker bar adjustment bolt; (7) flex die lip; (8) flex lip adjustment bolt; (9) lower lip; (10) die bolt; (11) heater cartridge.

The shear thinning causes the volumetric flow to be very sensitive to slight changes in die geometry. For example, the flow for a typical polymer melt through a slit will vary with the cubic thickness of the gap.

Thus, a small change in the die gap along the contour of the die exit may cause considerable change of the melt flow. The term “die swell” refers to the enlargement in the direction orthogonal to the flow direction.

Swelling after exiting the die lip is due to two distinct phenomena:^[4,5]

- Velocity relaxation (unification) of the melt flow.
- Viscoelastic relaxation of the strained polymer molecules.

Velocity relaxation occurs because the melt is no longer under shear from the no-slip walls of the extrusion die. The melt assumes a uniform bulk velocity that causes the high-speed areas to slow down and the areas previously retarded from the wall to increase their speed. The net result is enlarging (swelling) of the melt cross-section bulk as it exits the die, while the stagnant outside region and, especially, the corners are stretched and shrunk. Newtonian and non-Newtonian fluids exhibit die swell owing to velocity relaxation. The swelling due to viscoelastic memory is a characteristic of polymeric fluids and occurs because the polymer molecules are stretched in the flow direction while passing through the high-shear area before the die exit. On exiting, the molecules recoil and shorten in the flow direction. The result is an expansion in the direction orthogonal to the flow, a swelling of the diameter of a round strand on exiting the die, for example. The amount of viscoelastic swelling is a combination of the material properties of the polymer as well as process conditions such as melt temperature, shear rate, and residence time under high shear, especially near the die exit.^[6]





The design of extrusion dies today is facilitated by computer-based simulation tools. The flow of

non-Newtonian fluids through complex passages is routinely performed by computational fluid dynamics (CFD) programs.^[7-10] Factors such as shear thinning are readily accounted in die design. The viscoelastic behavior can also be modeled today, although this simulation requires extensive material testing to obtain the required material parameters for accurate simulation results. This is discussed in more detail later in this entry.

Extrusion dies vary in shape and complexity to meet the demands of the product being manufactured. There are five basic shapes of products made with extrusion dies, as illustrated in Table 1.^[11,12] Film and sheet dies are called slit dies as the basic shape of the die exit is a slit. Film is also made with annular dies as in the case of blown film. Strand dies make simple geometric shapes, such as circles, squares, or triangles. Pipe and tubing dies are called annular dies as the melt exits the die in the shape of an annulus. The inner wall of the annulus is supported with slight air pressure during extrusion. Open profile dies make irregular geometric shapes, such as “L” profiles or “U” profiles, and combinations of these. Hollow profile dies make irregular profiles that have at least one area that is completely surrounded by material. Examples of hollow profiles can be simple, such as concentric squares to make a box beam, or a very complex window profile.

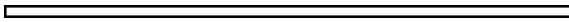
Each extruded product relies on a die to shape the moving melt followed by shaping and cooling devices downstream to form the extrudate into the final desired shape and size. A more complete treatment of these devices, which are typically water-cooled metallic

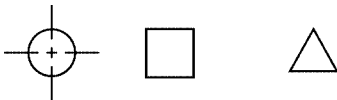
Table 1 Typical extruded product shapes

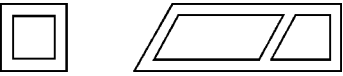
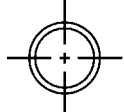
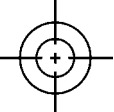
Films	$t < 0.01$ in.	
Sheets	$t > 0.01$ in.	
Profiles	Strand	
	Open	
	Hollow chamber	
Tubes	$d < 1.0$ in.	
Pipes	$d > 1.0$ in.	

devices that contact the extrudate melt, is presented later in the section “Extrudate Cooling and Sizing Hardware.”

SHEET DIES

The most common extrusion die for sheet products is the coat hanger-type manifold die as shown schematically in Fig. 1A and as a section view in Fig. 1B. The key elements of Fig. 1A are:

- Central inlet port: connects to the extruder barrel.
- Manifold: provides a streamlined channel to evenly distribute the melt to the island.
- Island: with the manifold serves to create an equal pressure drop from the die inlet to all points across the die exit.
- Die lip: wide slit across the die that provides the final sizing of the melt.

Commercial sheet dies typically employ four features to control the flow to the die lip. These are the combined shape of the manifold and the island as well as the following three features shown in Fig. 1B:

- Choker bar: adjustable along with the width of the die and serves to tune the flow balance across the width of the die.
- Lower lip: sets the nominal sheet thickness.
- Flex-lip: adjustable along the width of the die and provides the final tuning to create uniform flow across the die.

In addition, sheet dies have die bolts that hold the upper and lower die plates together. The die plates are normally heated with cartridge heaters spaced along the width of the die. This type of die is typically made for a specific type of polymer to account for the shear thinning behavior of that polymer.^[11] Consequently, the flow distribution in the die will change with melt viscosity, i.e., when the power law viscosity index of the resin changes. As the polymer grades change, flow adjustments can be made at the choker bar and at the flex lip, which both span the width of the die and can be adjusted at numerous points along the width. Clam shelling, or die deflection, is another cause of nonuniform flow across the die.^[13,14] The higher pressures along the centerline of the die coupled with the lack of bolting to keep the die plates together cause the centerline of the die gap to widen. Clam shelling can increase as the throughput of the die increases because of higher die pressures. Thus, the flow balance across the die will be sensitive to production rates. Innovations in automatic flow adjustments have been

made with designs like the Auto-Flex sheet die where the die lip gap at the flex lip is automatically adjusted by changing the length of the flex lip adjustment bolts.^[15,16] The temperature-controlled bolts change length in response to cross-machine scanning of the sheet thickness.

FLAT FILM AND BLOWN FILM DIES

Dies used to make film less than 0.01 in. thick include flat, slit-shaped dies called T-dies and annular dies for blown film (Figs. 2 and 3). The design of the T-die is similar to the coat hanger-type die with the exception that the manifold and the land length are constant along with the width of the die. Consequently, the use of T-dies is often limited to coating applications with low-viscosity resins that resist thermal degradation, as the ends of the manifold in the T-die create stagnation pockets.^[13] A common application for a film die is to coat a substrate like paper.

Blown film dies are the most common way of making commercial films. Because the blown film is so thin, weld lines are not tolerated, and the melt is typically introduced at the bottom of a spiral mandrel through a ring-shaped distribution system, as shown in Fig. 3. A series of spiral channels, cut into the mandrel-like multiple threads, smear the melt as it flows toward the die exit. This mixing action ensures that the melt is homogenous on exiting the die. Unlike other extrusion processes, blown film is sized and quenched from melt to solid film without contacting metallic cooling elements. The interior of the melt tube is pressurized with approximately 2 in. of water pressure. This pressure causes the tube to suddenly expand into a bubble as it exits the die. The tube forms a bubble because it is pinched overhead with nip rolls, which retain the air pressure. During the process of expanding, the melt tube undergoes an order of magnitude reduction in thickness and thus cools rapidly. This quenching moment occurs at the frost line of the bubble. The melt quenching occurs with a combination of external cooling air and internal bubble cooling air, as shown in Fig. 3. After the film passes through the nip rolls, it passes through a series of guide rollers to be wound up on to a roll.

PIPE AND TUBING DIES

Both pipe and tubing are made in dies with an annular die exit. A pipe product is defined as being greater than 1 in. in outer diameter and a tube less than 1 in. Dies for these products are made in two styles: 1) in-line dies (also called spider dies) shown in Fig. 4A and

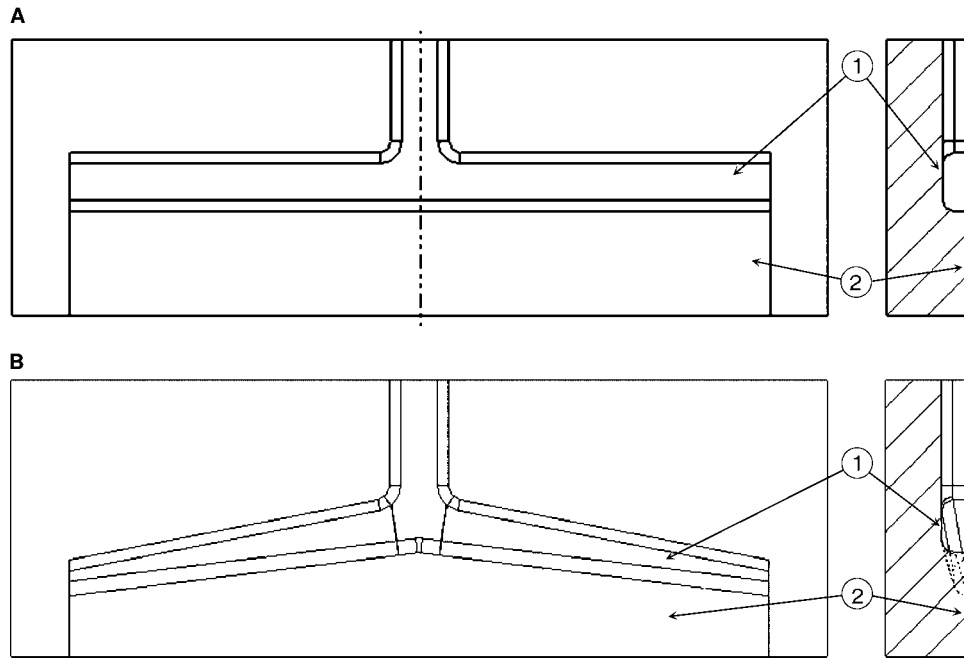

Fig. 2 Comparing designs of T-type die (A) [(1) constant cross-section manifold; (2) constant land length] to coat hanger-type die (B) [(1) manifold cross-section decreases as distance from centerline increases; (2) land length becomes shorter farther from the centerline of the die].

2) cross-head dies shown in Fig. 4B. The key elements of an in-line die are:

- **Housing:** mounts onto the end of the extruder, provides a circular passage through which the melt flows; it supports the mandrel and retaining ring.
- **Mandrel (Torpedo):** suspended in the center of the circular passage in the die body with metal bridges called spiders (typically three are used). One spider allows for passage of air into the center of the torpedo, is streamlined to avoid flow stagnation, and supports the die pin.
- **Die pin:** mates with the torpedo to provide streamlined sizing to the final inner diameter of the melt tube leaving the die; it has an air hole running through it to allow air to pass through the die body to the interior of the melt tube. A slight positive air pressure may be used to keep the inner diameter of the tubular extrudate from collapsing on exiting the die.
- **Die land:** forms the outer diameter of the tubular extrudate, held in place with a retaining ring and position adjusted with centering bolts. The die land can be changed to create a tube of a different diameter or wall thickness while keeping the original die pin.
- **Retaining plate:** secures the alignment of the die land with the die pin, bolted to the die body.
- **Heater band:** closely fitted to the housing (and for larger pipes to the exposed portion of the die pin) to ensure that the die is held at a temperature close to the required temperature of the melt.

- **Flange for extruder attachment:** tapered flange to permit alignment and attachment to extruder with split locking collars.

The in-line die is the least costly for manufacture of the two designs but can create defects called weld lines in the product. Weld lines occur because the melt is split and rejoined as it passes over the spider legs. A cross-head die can overcome this problem by eliminating the spiders. The melt enters the side of the die and turns 90° as it flows through a coat hanger-type passage that is wrapped around the mandrel. Key elements of a cross-head die that are different from an in-line tubing die are (see Fig. 4B):

- **Core tube:** mandrel with coat hanger-type passage that splits the flow and uniformly distributes melt along the annulus between the die pin and the die land.
- **Side feed:** melt enters from the side of the die and flows around the mandrel.
- **Air supply:** in-line with the die pin support.

Another application for the cross-head-style tubing die is wire coating. The following adjustments are made to a cross-head tubing die to perform wire coating:

- First, instead of passing air through the core tube, a bare conductor wire is pulled through the die entering the core tube inlet and exiting the die pin.

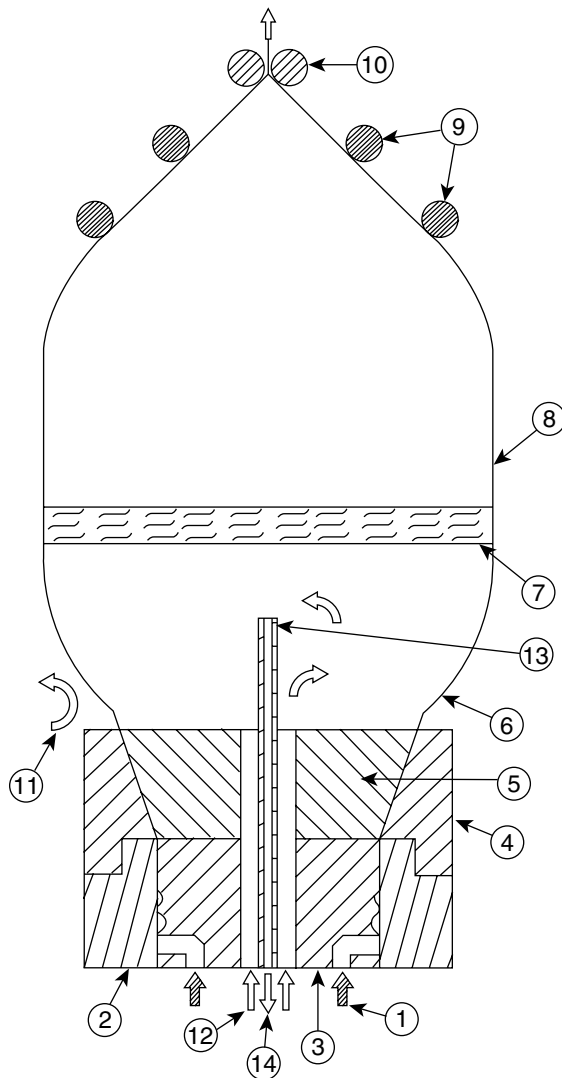

Fig. 3 Schematic of spiral mandrel blown film die operation: (1) ring-shaped melt distribution; (2) die body; (3) spiral flow mandrel; (4) sizing ring; (5) spreader; (6) film bubble; (7) frost line; (8) solidified film; (9) bubble collapsing rollers; (10) nip rollers; (11) external bubble cooling air; (12) internal bubble cooling air inlet; (13) internal bubble cooling pipe; and (14) heated internal bubble air return.

- Second, the length of the die pin is shortened to cause the wire to contact the melt tube before it exits the die land.

PROFILE EXTRUSION DIES

Profile extrusions are the most difficult to make because changes in take-up speed or screw rotational speed alone are not enough to compensate for deficient product dimensions. In the case of sheet and film, if the edges of the sheet are not at the target thickness, they can be trimmed off and sent back to the extruder

to be reprocessed. Profile extrudates are significantly affected by nonuniform die swell unlike sheet and tube products. In the case of profiles with corners and other irregularities, like a square profile, the die exit needed to achieve a square profile is not square owing to the influence of die swell. Fig. 5 illustrates a die exit required to achieve a square extrudate. Note that the corners have an acute cusp shape and the side walls are not flat. A melt exiting this required but nonorthogonal shape will swell into a desired, orthogonal square shape. The design of nonorthogonal die exit required to achieve orthogonal profiles is addressed later in this entry in the section Modern Design Simulation and Computational Tools.

Open profile dies are typically shapes, such as “U-shaped” or “L-shaped” channels, that are not axisymmetric, unlike tube shapes. Consequently, open profiles are more prone to cooling unevenly and thus may generate residual stresses in the solidified (frozen) extrudate that cause the product to bow. A critical design rule for open profiles is to maintain a uniform wall thickness throughout the product cross section. Examples of poor and better profile designs are shown in Fig. 6 with the poorly designed sections shown on the left-hand side and the improved designs on the right-hand side. The difficulty with the original designs of both profiles A and B is the nonuniform wall thickness. The thinner sections will solidify first with the thicker sections still remaining molten in some core area. The result will be additional thermal shrinkage in the thicker regions and thus warpage of the final product. Product A will warp downward and product B will warp toward the right. These warping problems can be alleviated by making the entire cross section with more uniform thickness. Then, the entire cross section will solidify more uniformly and a little residual stress will be trapped in the solid extrudate. Design A illustrates a case where a hollow profile is used to solve the warpage problem whereas design B illustrates the use of an open profile to replace the thick region. The revised product designs of A and B will require more expense to fabricate the dies for these products as a set of mandrels must be made to form the hollow chambers. However, there are key benefits derived by making these changes:

- Better-quality products due to more uniform cooling and shrinkage: straighter products.
- Less material use by removing thick, unnecessary regions: savings of material costs.
- Faster cooling rates due to less hot plastic to cool: higher production rates.

Profile dies are commonly made with a series of plates that are stacked together to form a complex

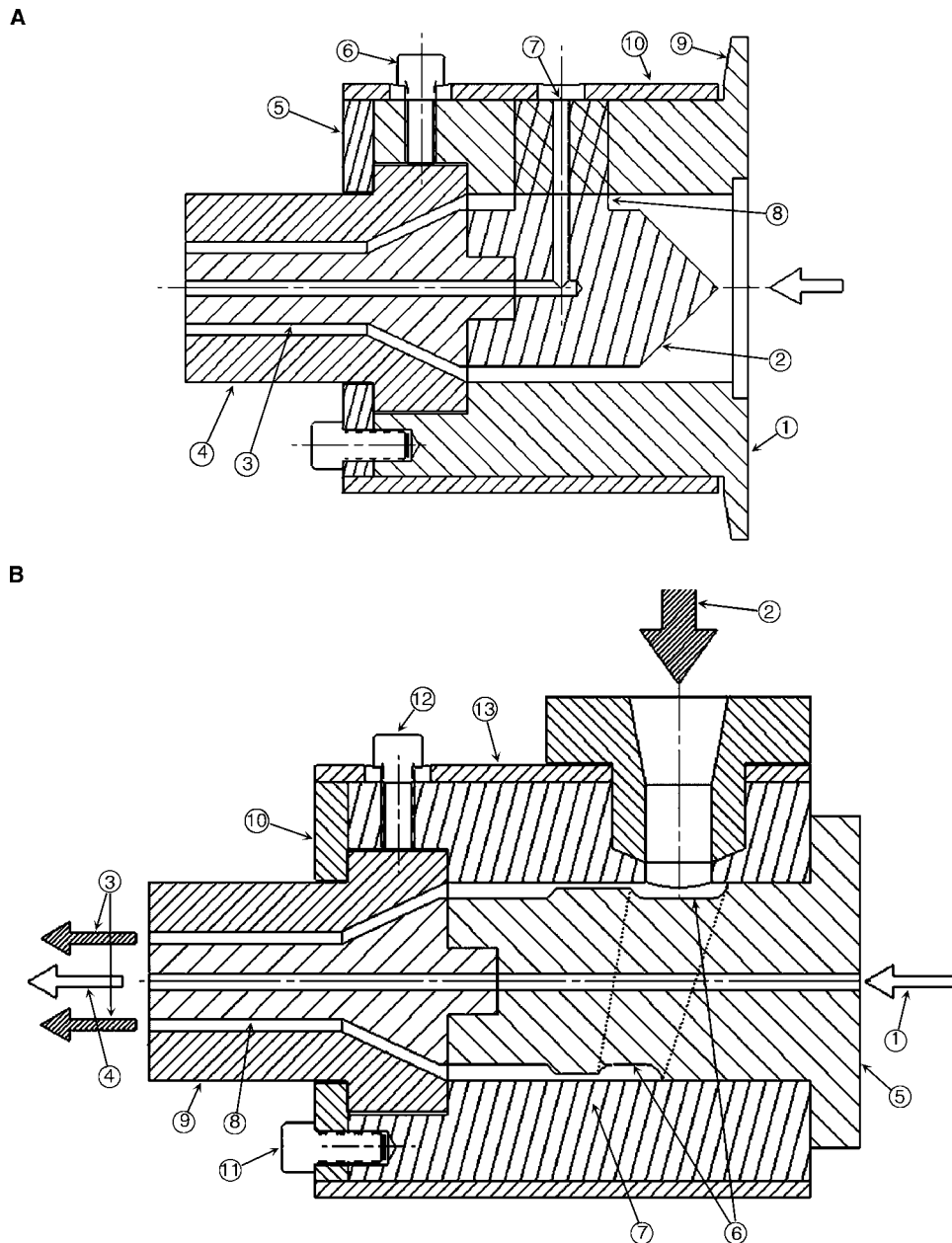

Fig. 4 Schematic of in-line tubing die (A): (1) housing; (2) mandrel (torpedo); (3) die pin (interchangeable); (4) die land (interchangeable); (5) retaining plate; (6) die centering bolt; (7) air hole; (8) mandrel support (spider leg); (9) die flange (mount to extruder with split clamp); (10) heater band; and cross-head tubing (or wire coating) die (B): (1) air or wire conductor inlet; (2) melt inflow (side inlet); (3) melt exit (annulus); (4) air or wire conductor exit; (5) core tube; (6) flow splitter; (7) housing; (8) die pin; (9) die land; (10) retaining plate; (11) retaining ring bolt; (12) die centering bolt; (13) heater band.

passage from the circular exit of the extruder to the required profile die exit. A stacked plate design makes for easier manufacture and permits adjustments to parts of the die assembly as needed during extrusion trials to fine-tune the die flow. An example of a stack plate die that makes a U-shaped profile is shown in Fig. 7. This figure illustrates an exploded view of a stack plate die, a cross-sectional view of the assembled

die, and a detail of the die exit compared to the target profile. Stacked plate profile dies typically have these elements:

- Adapter plate: forms transition from circular extruder exit to approximate profile shape.
- Transition plate: forms streamlined transition from adapter plate exit to preland plate inlet.

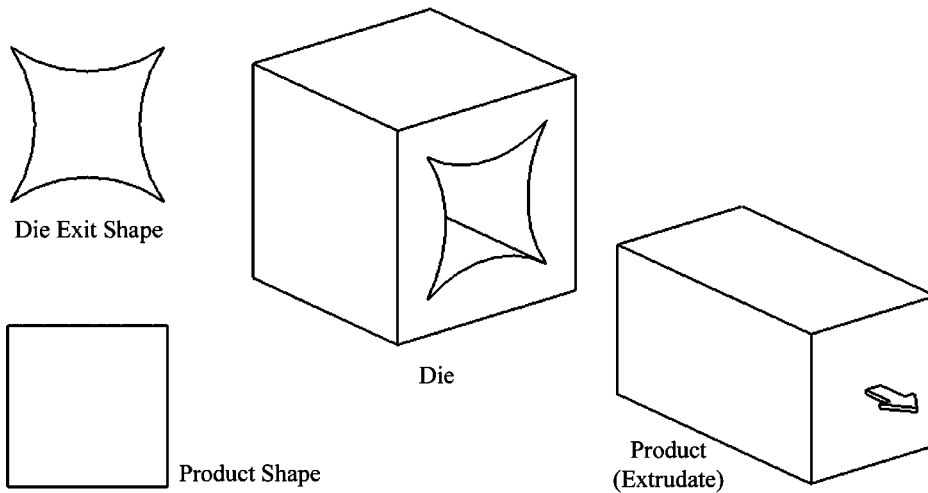

Fig. 5 Irregular die shapes required for regular extrudates.

- Preland plate: imparts significant flow adjustment by reducing thickness in high-flow areas and increasing thickness in low-flow areas anticipated downstream in the die land to make flow more uniform.
- Die land plate: provides a uniform cross-section passage that is typically 10 times longer than the thickness of the extrudate to relax the viscoelastic stresses in the melt before leaving the die (reduces die swell) and forms the shape of the extrudate leaving the die. The die land profile has the required shape to compensate for extrudate deformation after the die (die swell and drawdown) and yield the desired shape downstream.

The die exit profile shown in Fig. 7 creates an extrudate that is a U-shaped profile with three sides

of uniform thickness and perpendicular walls to the bottom surface. The irregular shape of the die exit was generated with the aid of CFD as outlined in the section Modern Design Simulation and Computational Tools later in this entry.

COEXTRUSION DIES

Another important product made with extrusion dies is the creation of multilayered materials. Multilayered sheet and film materials have two applications:

- Making more economical material by sandwiching a less costly core material between two more expensive materials.

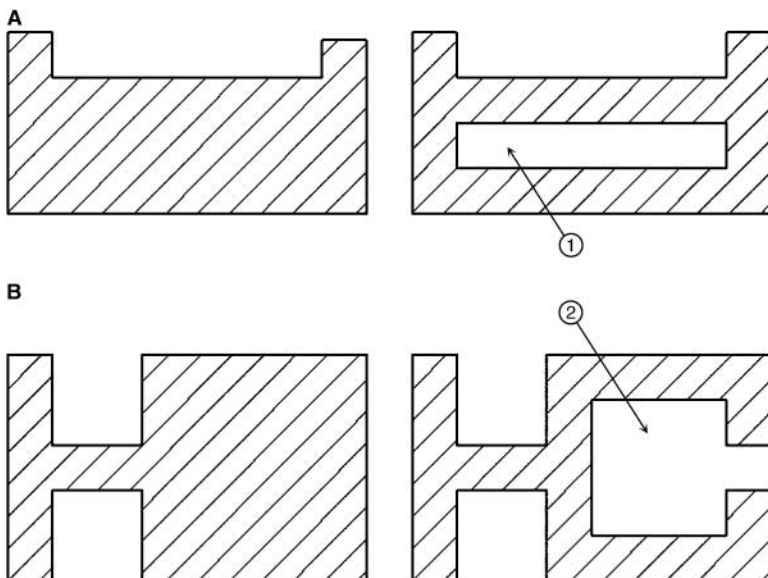

Fig. 6 Examples of poor (on left) and improved extrusion product designs (on right) to achieve uniform product thickness: (1) profile (A) made into a hollow profile and (2) profile (B) made into an open profile.

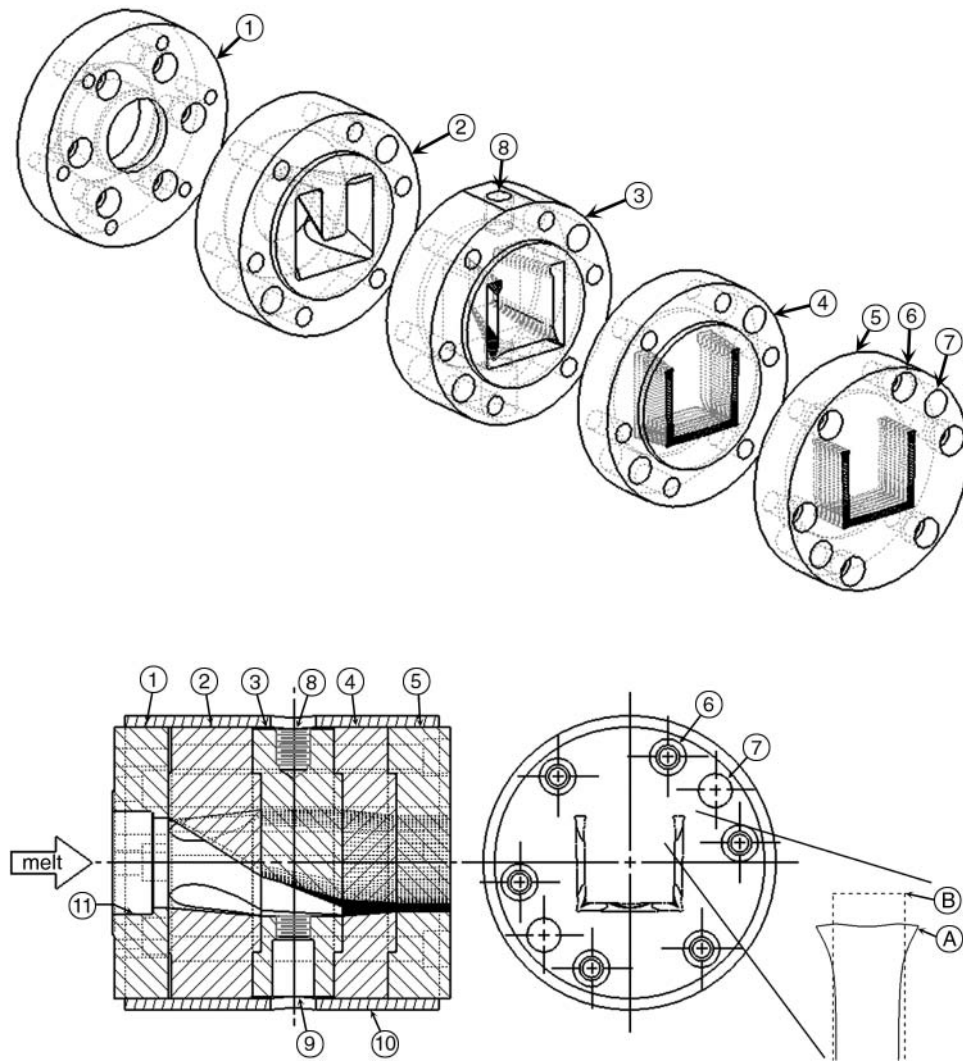

Fig. 7 U-Profile stack die: exploded view (top); section view (lower left); and end view (lower right): (1) extruder mounting plate; (2) die adapter plate; (3) transition plate; (4) preland plate; (5) die land plate; (6) die bolt hole; (7) alignment dowel pin hole; (8) thermocouple well; (9) pressure transducer port; (10) heater band; (11) breaker plate recess. Detail (lower right): (A) die exit profile and (B) product profile.

- Creating a composite material with improved properties by combining two or more materials that each possess a desirable property.

Applications of coextruded material include:

- Sheet stock made with an acrylic topcoat over acrylonitrile-butadiene-styrene (ABS). The acrylic provides UV resistance and gloss while the ABS provides impact resistance.
- Blown film with special barrier properties: one layer limits oxygen migration through the film and another provides protection from UV radiation.

There are two common methods of achieving co-extruded materials: feed block manifolds and

multimanifolds within dies.^[17] Two, three, or more melt streams may be combined with co-extrusion dies. The key elements of a feed block manifold as shown in Fig. 8A are:

- Inlet ports for the upper layer, middle layer, and lower layer.
- Streamlined melt lamination area that channels separate flow streams into one laminated melt stream inside feed block.
- Adapter plate between the feed block and the sheet die.
- Sheet die, which is identical to a monolayer die. The laminated melt stream enters the center of the die and spreads out along the manifold flowing out of the die exit as a distinct multilayer extrudate.

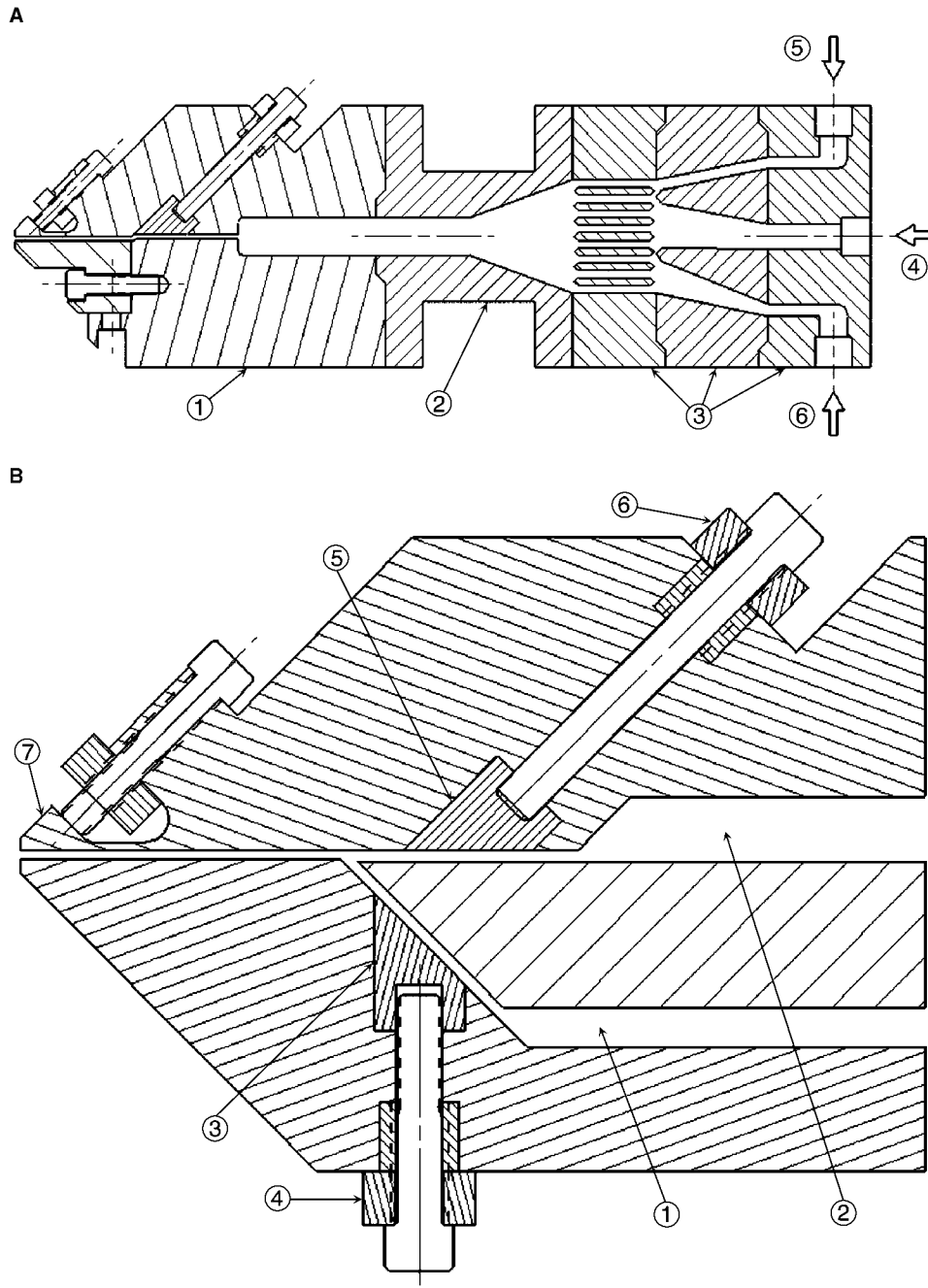

Fig. 8 Coextrusion feed block manifold and sheet die (A): (1) sheet die with flow restriction; (2) adapter plate; (3) feed block assembly; (4) core material layer inlet; (5) upper material layer inlet; (6) lower material layer inlet; and coextrusion multimanifold sheet die (B): (1) lower melt channel; (2) upper melt channel; (3) lower choker bar; (4) lower choker bar adjustment bolt; (5) upper choker bar; (6) upper choker bar adjustment bolt; (7) flex lip.

An alternative to the feed block design is a multi-manifold die as depicted in Fig. 8B. The key elements of this design are:

- It is similar to a monolayer extrusion die, except that there is more than one feed channel.
- Each melt channel has its own choker bar for flow control.

- Melt streams converge inside the die near the die exit and emerge as a distinct multilayer extrudate.

The feed block technique is cheaper to implement than the multimanifold approach, but because the melt streams travel some distance before reaching the die exit, irregular flow patterns can develop at the interface of the different melt streams.^[18–20] This is especially

true when attempting to coextrude melts of significantly differing viscosities. Lower-viscosity melt tends to encapsulate the more viscous melt. The alternative method is to keep the melt streams separated until just before the die exit as is done with the multimanifold design. Multimanifold designs permit coextrusion of plastic melts having significantly differing viscosities. With any coextrusion process, however, there must exist basic chemical compatibility between the neighboring melt streams to ensure good cohesion between the layers.

EXTRUDATE COOLING AND SIZING HARDWARE

With the exception of blown film and strand profiles, all extrudates require cooling and/or sizing by some metallic element. Table 2 summarizes the type of cooling and sizing hardware used for the various extrusion products.^[21] In the case of sheet extrusion, the cooling is achieved with a chill roll stack, schematically illustrated in Fig. 9. The chill rolls are typically highly polished chrome-plated rollers that impart the surface gloss on sheet products and cool the extrudate while pulling the melt away from the die with a constant take-up speed. The average sheet thickness is achieved by the combination of extrusion screw rotational speeds and take-up speed adjustments. If the line speed taking the extrudate melt away from the die is greater than the average die exit speed, the thickness of the sheet decreases. This is called drawdown.

In the case of pipe and tubing products, the nominal outer and inner diameters of the extrudate are made by selecting the appropriate size of the die pin and die land. The final outer dimension of tubing products is achieved with sizing rings that are typically placed in the vacuum water bath, shown schematically in Fig. 10. The outer diameter of the tube is set with the sizing ring as the vacuum, which combined with a slight positive pressure inside the tube, forces the

extrudate against the inner race of the ring. The desired inner diameter of the tube is achieved by adjusting the take-up speed of the extrudate relative to the average die exit speed. If the take-up speed is greater than the average die exit speed, the cross-sectional area decreases. Because the outer diameter of the tube is set with a sizing ring, the inner diameter will increase. Thus, the wall thickness of a tube is controlled this way.

The sizing and cooling of profiles have special requirements because of their complex shape.^[21,22] These devices are called calibrators and are often as complicated as the die. To maintain the shape of a profile, vacuum is applied while simultaneously cooling the extrudate. Some calibrators, called wet vacuum calibrators, alternately inject water between the extrudate and the calibrator to lubricate and augment the cooling. A schematic of the dry vacuum calibrator setup used to size and cool the U-shaped profile is shown in Fig. 11. Fig. 11B illustrates a partially disassembled vacuum calibrator to reveal the following details: the vacuum channels and the cooling lines that simultaneously hold the moving extrudate in the desired shape while cooling it. Vacuum calibrators for profiles are typically made of stainless steel to withstand the abrasive action of extrudates while in contact with the calibrator during the cooling process. For example, the U-profile shown in Fig. 11 will tend to shrink onto the core feature of the lower calibrator and pull away from the upper calibrator surfaces. This complicates the design of the calibrator as the extrudate will conform to the ideal calibrator shape as it deforms. The cooling of the extrudate also complicates the simulation and design of the calibrator as discussed in the next section.

MODERN DESIGN SIMULATION AND COMPUTATIONAL TOOLS

The development of powerful computing hardware and proficient numerical techniques makes it possible now to simulate, analyze, and optimize three-dimensional extrusion processes with complex geometries, including nonlinear and viscoelastic polymer behavior. Numerical simulation has the potential to uncover important interior details of the extrusion process, such as velocity, shear stress, pressure, and temperature fields in the region of interest, which is not possible to do experimentally. A critical challenge for simulation methods is the ability to accurately represent the complex viscoelastic polymer material behavior that is dependent on process parameters, like shearing flow rate and temperature. Another challenge is to accurately model the complex geometry and the boundary conditions of extrusion dies and calibrators, especially for profile extrusions.

Experts in the polymer processing field have cited that the increasing complexity of product designs, coupled

Table 2 Cooling and sizing devices for various extruded products

Product type	Cooling and sizing device
Film and sheet	Chill roll
Blown film	External and internal bubble air
Profiles—strand	Water tank
Profiles—open and hollow chamber	Vacuum calibrators and water tank
Tubing and pipes	Sizing rings and vacuum water tank

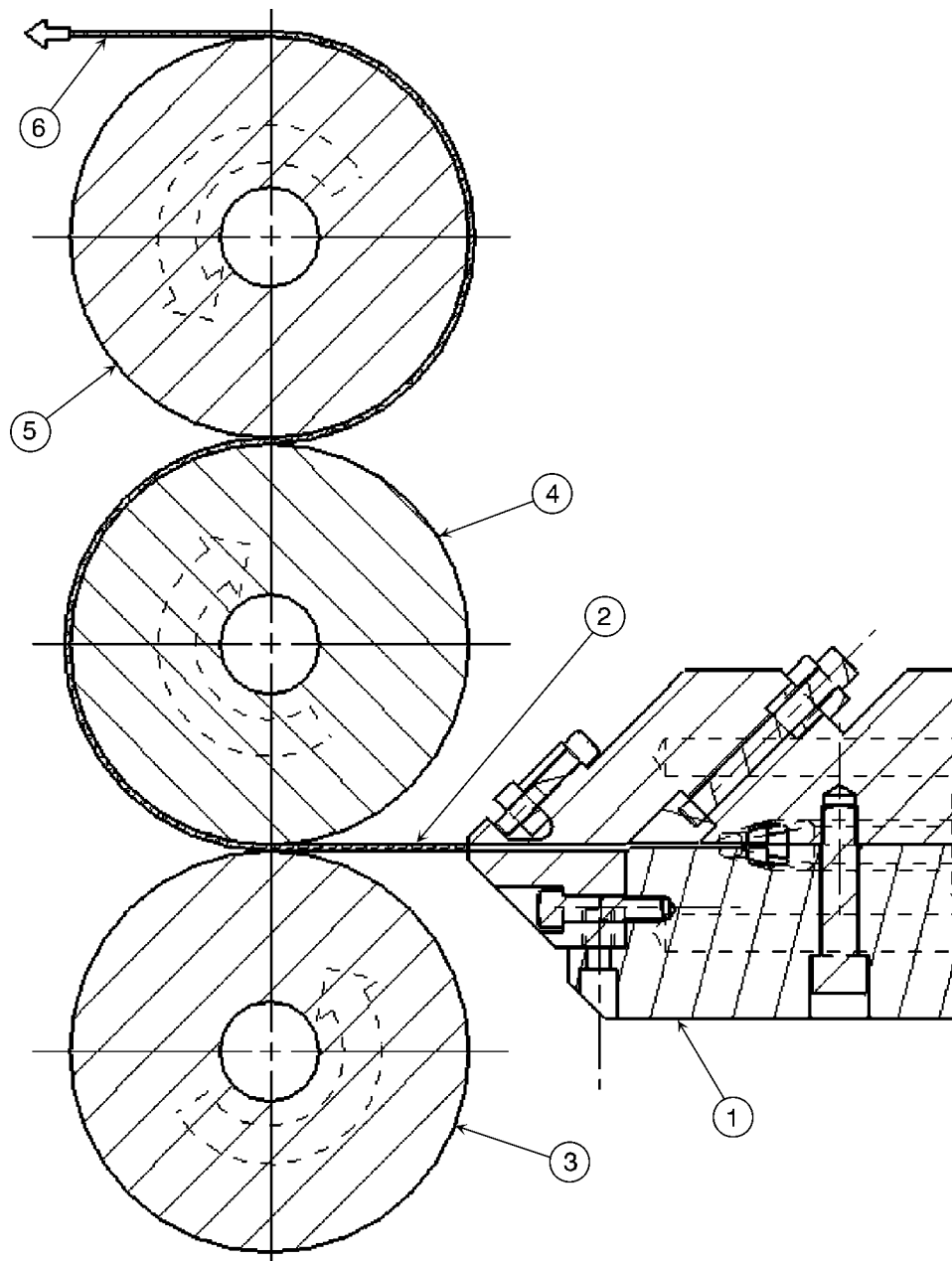

Fig. 9 Chill roll stack for sheet extrusion: (1) sheet die with flow restrictor; (2) molten sheet extrudate; (3) lower chill roll (all chill rolls temperature controlled); (4) middle chill roll (imparts gloss/surface texture to sheet); (5) upper chill roll; and (6) solidified sheet.

with the shorter development times, and a shortage of qualified engineers fuel the need for more process simulation in industry.^[23] As already stated, several commercial polymer flow simulation programs are used for profile die design.^[7–10] However, because the cooling rate of the extruded product determines the speed of the extrusion line, optimal design of a calibrator is also critical to productive operations. In addition, the design of the calibrator has an influence on the straightness of the final product because of uneven cooling results in unfavorable thermal deformations and warped products.^[24]

Analytical solutions have been developed to aid the design of calibrators for simple shapes, such as sheets and pipes.^[22] More complex shapes, such as window profiles, require the use of numerical finite element methods that can model arbitrary shapes.^[25]

Computational Fluid Dynamics Simulation of Polymer Flow for Die Design

The design process begins with a target product shape. The objective of the simulation is to determine

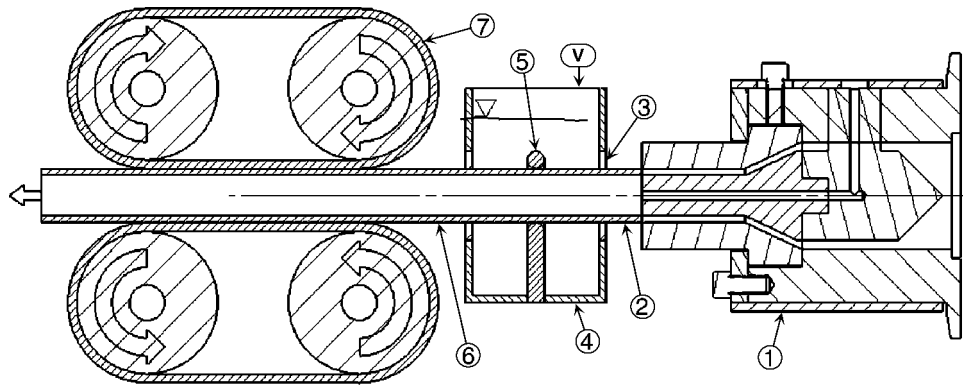

Fig. 10 Tubing vacuum water-bath calibration and take-off: (1) tubing/pipe die; (2) molten tube extrudate; (3) baffle; (4) vacuum water tank; (5) sizing ring; (6) solidified tube; and (7) puller.

the required die passage that results in a balanced mass flow exiting the die and an extrudate shape downstream of the die that matches the target profile.

A commercial polymer flow simulation program was used to simulate the three-dimensional die flow and heat transfer through the U-profile die, shown in Fig. 12.^[7,26] Because the last two die plates have the greatest influence on the extrudate profile shape, only

these two plates are designed with flow simulation. Simulation requires the following inputs:^[7]

1. Geometric model of the die passage
 - a. Two-dimensional profile of the inlet plane of the passage
 - b. Two-dimensional profile of the target extrudate shape.

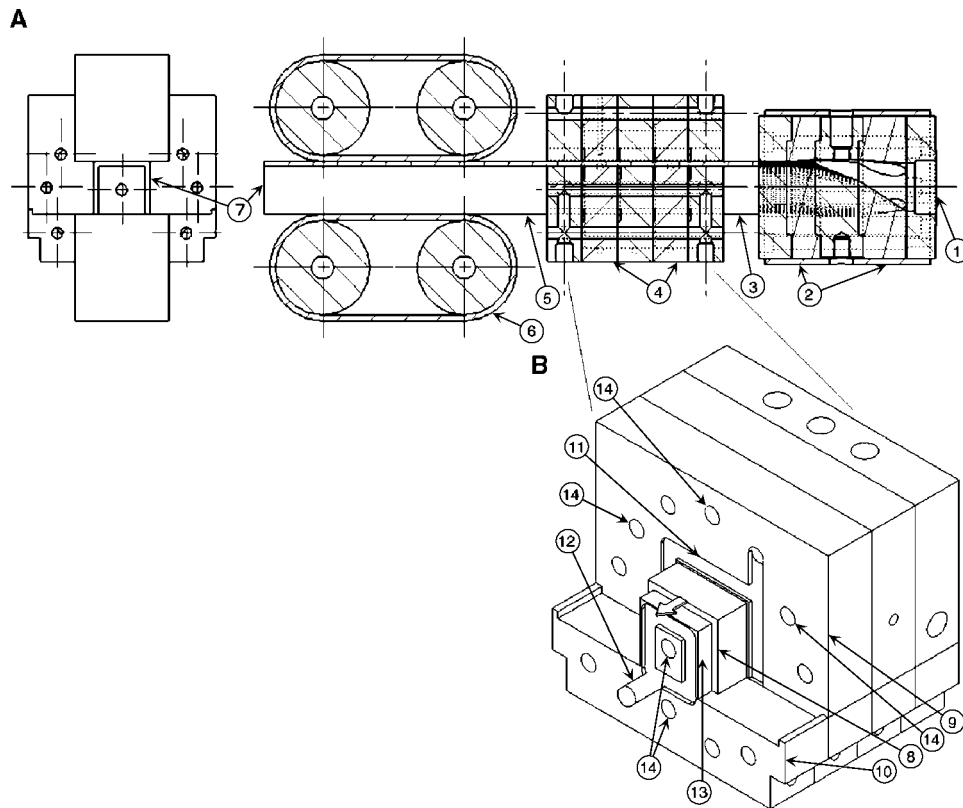

Fig. 11 Profile vacuum calibration and take-off. (A) Section view of calibration process: (1) melt enters profile die; (2) profile die stack; (3) molten profile extrudate; (4) calibrator (cools, shapes, and sizes extrudate); (5) solidified plastic; (6) puller; (7) orientation of profile. (B) Partially disassembled calibrator: (8) profile passing through calibrator; (9) upper calibrator stack; (10) lower calibrator stack; (11) upper vacuum channel; (12) lower vacuum channel; (13) core feature of lower calibrator; (14) cooling line.

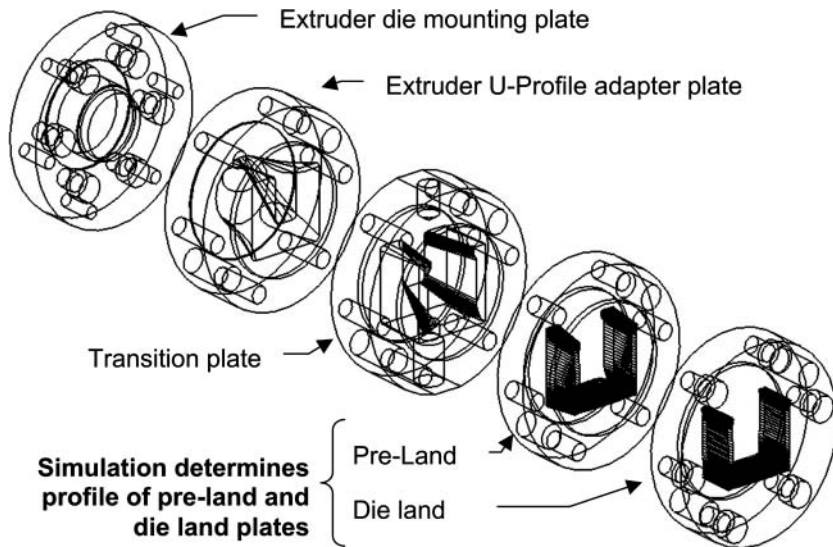

Fig. 12 U-Profile die plates designed with CFD simulation.

- c. Specification of the preland length, the die land length (note that die land has a constant cross-sectional profile), and the free surface flow length after the die exit.
2. Thermomechanical properties of the polymer melt: density, heat capacity, and thermal conductivity.
3. Rheological properties of the polymer melt: non-Newtonian viscosity as a function of shear rate and temperature and/or viscoelastic material characteristics.
4. Process conditions: inlet melt temperature, mass flow rate into the die passage (or pressure at the inlet), die wall temperature, and take-up speed of the extrudate downstream from the die.

The computational domain resembles the real three-dimensional die geometry and a free surface flow after the die, where velocity redistribution (equalization) and stress relaxation take place in a short distance downstream from the die exit (Fig. 13A). Because of the symmetry of the die design, only half of the die passage is modeled (Fig. 13B). A finite element model of the die passage and the free surface region consists of 16,592 hexahedral elements and 19,530 nodes, as detailed elsewhere.^[26] The computational domain must have appropriate boundary conditions to represent the realistic conditions present as the melt passes through the die and exits into a free surface flow (Fig. 13C). The used commercial CFD program implements an “inverse extrusion” solution algorithm, which computes the shape of the die exit (die land profile) required to achieve the target profile dimensions at the exit of the free surface domain.^[7] The program solves for the shape of the

die land that will achieve the target profile after die swell occurs.^[7,26]

Cooling Simulation and Calibrator Design

For optimal design of the profile extrusion calibrators, cooling bath, and other cooling accessories, a comprehensive knowledge about the extrudate heat transfer process (cooling) is necessary. The biggest challenge in modeling of profile extrudate cooling is to specify properly the boundary conditions in every local part of the cooling equipment. It is possible to approximate heat transfer coefficients or determine the values experimentally.^[27,28] It may be very difficult to estimate the heat transfer coefficient in a vacuum calibrator because it is not possible to predict, without experimental verification, where the polymer has a good contact with the cooling wall and what is the influence of a thin layer of cooling water being sucked in from the cooling bath. However, even estimated values can be used to get a good overall picture of the process, as the polymer materials have a fairly low thermal conductivity. This means that the obtained results are not exact, but they can be very useful for design. Therefore, the modeling and simulation of extrudate cooling is a useful tool for studying the profile extrusion cooling process, as well as for design improvement of the calibrators and other cooling equipment. Other researchers also indicated that calibration design can be done to estimate the cooling performance.^[29,30] An illustration of the type of information that can be obtained by simulating the cooling of the extrudate is shown by cooling simulation of a U-profile extrudate using a commercial simulation program and

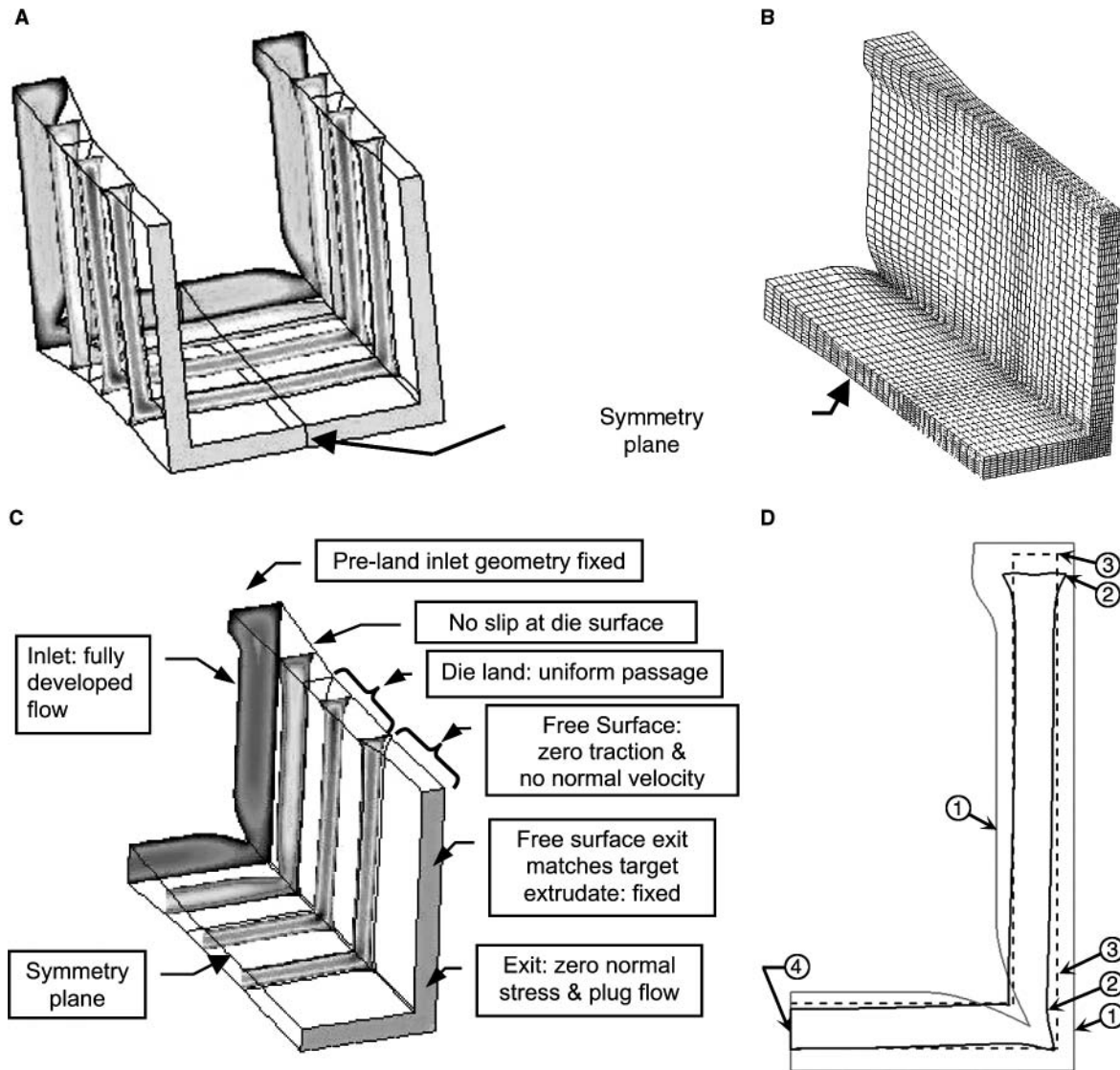

Fig. 13 Computational model for U-Profile die design: (A) preland, die land, and free surface as computational domain; (B) finite element mesh (symmetry exploited to reduce computational requirements); (C) boundary conditions for simulation of polymer flow through die and extrudate free surface; and (D) relevant profiles: (1) preland inlet; (2) die land (uniform along flow length); (3) final free surface (target extrudate profile); and (4) symmetry plane.

experimentally determined heat transfer coefficients in a vacuum calibrator.^[26]

CONCLUSIONS AND DESIGN RECOMMENDATIONS

As stated above, extrusion die design is a complex task because the extrudate product dimensions depend not only on the die design (die shape), but also on the polymer properties and extrusion process parameters. The following are general recommendations for extrusion die design:

- Achieve a balanced melt flow exiting the die.
- Minimize the pressure drop required to achieve a balanced flow to permit the maximum mass flow rate with the smallest-sized extruder required.
- Provide flow control devices in the die to optimize the flow distribution.
- Streamline the die flow passage to avoid flow stagnation areas. Such areas facilitate degradation of the polymer melt due to prolonged exposure at elevated temperatures.
- Use modular design with stacked plates for manufacturability, convenient assembly, and disassembly, as well as convenient modifications and cleaning.
- Die land length should be at least 10 times the product thickness (or gap) to facilitate the polymer melt stress relaxation within the die.

- Avoid thick and nonuniform extrudate wall thickness to achieve better flow balance control in the die, minimize material use, reduce cooling times, and minimize postextrusion warping of the product.
- Avoid or minimize hollow profiles as they increase die fabrication costs and complicate the cooling process of the extrudate.

Except for circular dies, it is virtually impossible to design a die geometry to achieve a quality extrudate product for a wide range of polymers and extrusion process conditions. That is why a good die design must incorporate appropriate adjustment features to be set (or tuned) during the extrusion process to compensate for the deficiency of the final product, i.e., the cooled extrudate. For a fixed die geometry, adjustment of the deficient profile may be achieved by changing extrusion process parameters, like temperature, flow rate, cooling rate, and/or take-up speed. However, it is important to optimize the die design to make the necessary adjustments practically possible. This is why polymer extrusion die design has most often relied on experience, empirical data, and expensive trial and error adjustments to design and optimize a die and complementary process parameters. However, by integrating computational simulation with empirical data and by improving the extrusion monitoring instrumentation the die design process can be improved. A better die design method yields improved product quality and a reduction in the time to design and optimize the extrusion process, resulting in lower costs. It is important to state again that computational simulation and empirical extrusion engineering are synergistic in nature. They have their exclusive strengths and weaknesses that cannot replace each other, but, if properly integrated, may significantly improve extrusion die design.

REFERENCES

1. Tadmor, Z.; Gogos, C.G. Die forming. In *Principles of Polymer Processing*; John Wiley & Sons, 1979; 521–524.
2. Rosato, D.V. Die design and performance. In *Extruding Plastics*; Chapman & Hall, 1998; 228–282.
3. Rauwendaal, C. Die forming. In *Understanding Extrusion*; Hanser, 1998; 107–109.
4. Tadmor, Z.; Gogos, C.G. Polymer melt rheology. In *Principles of Polymer Processing*; John Wiley & Sons, 1979; 148–172.
5. Michaeli, W. Monoextrusion dies for thermoplastics. In *Extrusion Dies for Plastics and Rubber*, 2nd Ed.; Hanser, 1992; 195–198.
6. Woei-Shyong, L.; Hsueh-Yu, H. Experimental study on extrudate swell and die geometry of profile extrusion. *J. Polym. Eng. Sci.* **2000**, *40* (5), 1085–1094.
7. Polyflow (application software); Fluent Inc.: Lebanon, NH; <http://www.fluent.com/software/polyflow> (accessed Mar 2005).
8. Flow 2000; Compuplast International: Zlin, Czech Republic; http://www.compuplast.com/FLOW_2000.htm (accessed Mar 2005).
9. Dieflow: Chippewa Falls WI; <http://www.dieflow.com> (accesses Mar 2005).
10. HyperXtrude, Altair Engineering, Inc.: Troy, MI; http://www.altair.com/software/hw_hx.htm (accessed Mar 2005).
11. Michaeli, W. Monoextrusion dies for thermoplastics. In *Extrusion Dies for Plastics and Rubber*, 2nd Ed.; Hanser, 1992; 128–194.
12. Levy, S.; Carley, J.F. Extrusion dies for specific product lines. In *Plastics Extrusion Technology Handbook*, 2nd Ed.; Industrial Press, Inc., 1989; 96–139.
13. Extrusion Dies Industries, LLC: Chippewa Falls, WI; <http://www.extrusiondies.com> (accessed Mar 2005).
14. Michaeli, W. Monoextrusion dies for thermoplastics. In *Extrusion Dies for Plastics and Rubber*, 2nd Ed.; Hanser, 1992; 147–148.
15. Levy, S.; Carley, J.F. On-line and computer control of the extrusion process. In *Plastics Extrusion Technology Handbook*, 2nd Ed.; Industrial Press, Inc., 1989; 302–304.
16. Tadmor, Z.; Gogos, C.G. Die forming. In *Principles of Polymer Processing*; John Wiley & Sons, 1979; 533–537.
17. Michaeli, W. Coextrusion dies for thermoplastics. In *Extrusion Dies for Plastics and Rubber*, 2nd Ed.; Hanser, 1992; 234–238.
18. Levy, S.; Carley, J.F. Extrusion dies for specific product lines. In *Plastics Extrusion Technology Handbook*, 2nd Ed.; Industrial Press, Inc., 1989; 228–233.
19. Gifford, W.A. A three-dimensional analysis of coextrusion in a single manifold flat die. *J. Polym. Eng. Sci.* **2000**, *40* (9), 2095–2100.
20. Michaeli, W. Coextrusion dies for thermoplastics. In *Extrusion Dies for Plastics and Rubber*, 2nd Ed.; Hanser, 1992; 215–221.
21. Levy, S.; Carley, J.F. Extrusion dies for specific product lines. In *Plastics Extrusion Technology Handbook*, 2nd Ed.; Industrial Press, Inc., 1989; 188–213.
22. Michaeli, W. Calibration of pipes and profiles. In *Extrusion Dies for Plastics and Rubber*, 2nd Ed.; Hanser, 1992; 311–326.

23. Michaeli, W.; Pfannschmidt, O.; Franz, A.; Vogt, N. Pre-computing developments—progress report on process simulation in industry. *Kunststoffe* **2001**, *91* (7), 32–39.
24. Brown, R.J. *Predicting How the Cooling and Resulting Shrinkage of Plastics Affect the Shape and Straightness of Extruded Products*. Proceedings of the Annual Technical Conference of the Society of Plastics Engineers, May 4–8, 2000.
25. Sheehy, P.; Tanguy, P.A.; Blouin, D. A finite element model for complex profile calibration. *J. Polym. Eng. Sci.* **1994**, *34* (8), 650–656.
26. Reifschneider, L.G.; Kostic, M.K.; Vaddiraju, S.R. *Computational Design of a U-Profile Die and Calibrator*. Proceedings of the Annual Technical Conference of the Society of Plastics Engineers, Chicago, May 16–20, 2004.
27. Michaeli, W. Calibration of pipes and profiles. In *Extrusion Dies for Plastics and Rubber*, 2nd Ed.; Hanser, 1992; 324–329.
28. Fredette, L.; Tanguy, P.A.; Hurez, P.; Blouin, D. On the determination of heat transfer coefficient between PVC and steel in vacuum extrusion calibrators. *Int. J. Num. Methods Heat Fluid Flow* **1996**, *6*, 3–12.
29. Placek, L.; Svabik, J.; Vlcek, J. *Cooling of Extruded Plastic Profiles*. Proceedings of the Annual Technical Conference of the Society of Plastics Engineers, May 4–8, 2000.
30. Carneiro, O.S.; Nobrega, J.M.; Covas, J.A.; Oliveria, P.J.; Pinho, F.T. *A Study of the Thermal Performance of Calibrators*. Proceedings of the Annual Technical Conference of the Society of Plastics Engineers, Chicago, May 16–20, 2004.